

The Simple Summer Shift

A beginner-friendly blueprint for a classic, zipper-free linen dress

Estimated Time: 3-5 Hours | 3 Size Ranges + Kids Variant

The Perfect Entry Garment

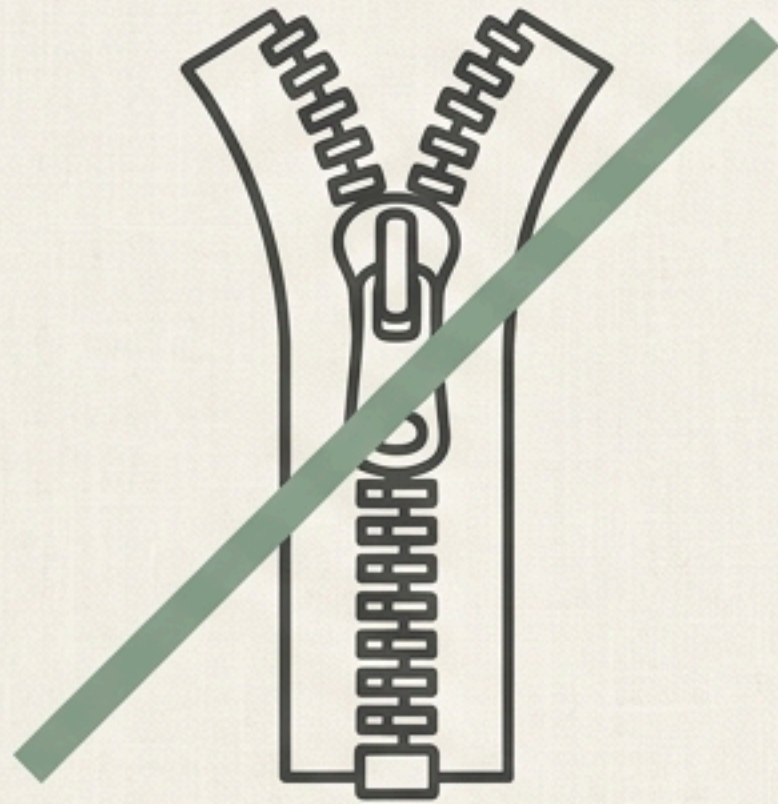

No Zippers

The neckline opening is mathematically graded to clear the head with 2" of ease.

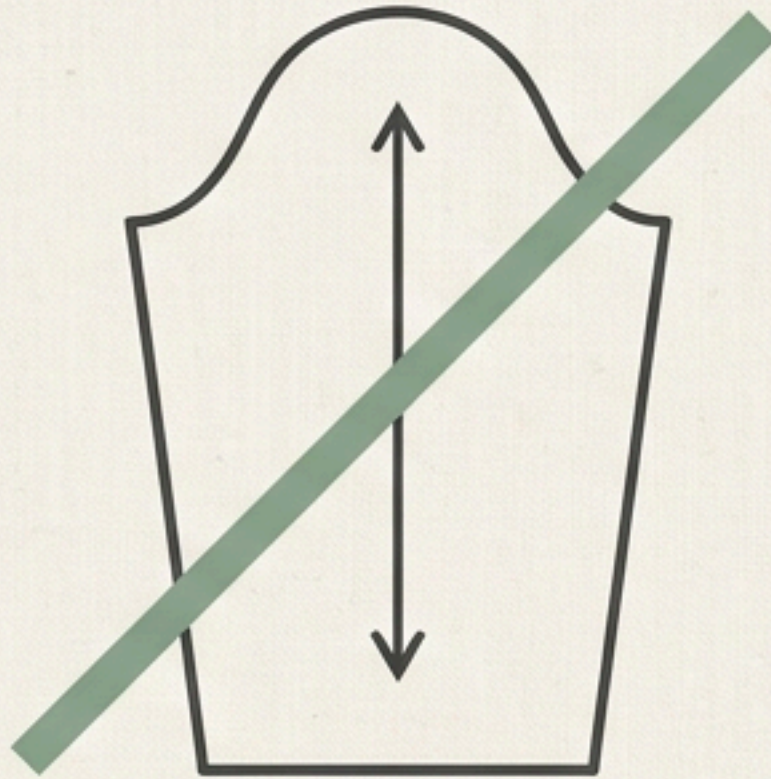

No Set-In Sleeves

Grown-on shoulder shaping removes the second most common garment failure point.

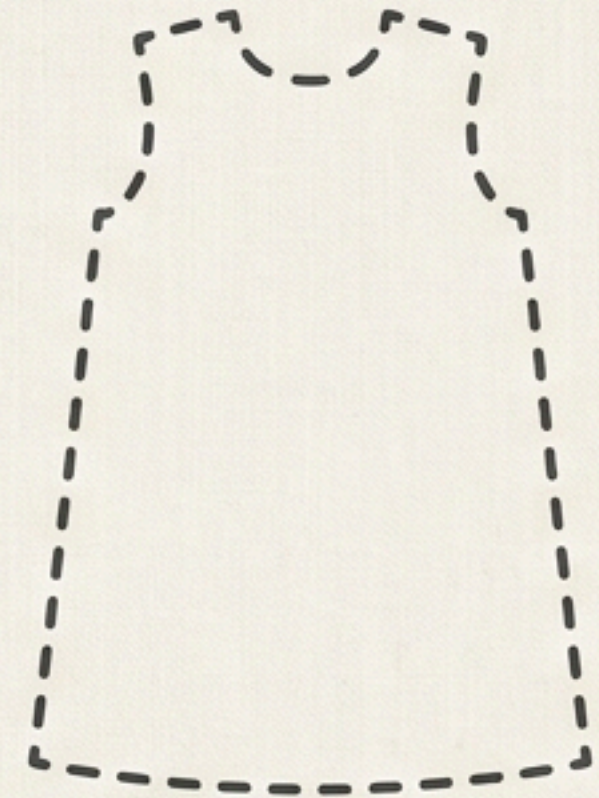

Forgiving Fit

The boxy cut absorbs minor seam width variations without ruining the final silhouette.

Three Transferable Skills

Completing this project unlocks the core techniques required for every woven garment you make next:



Step 1

Sewing and pressing a straight woven seam.



Step 2

Applying seam finishes to control fraying.



Step 3

Completing a structured, faced neckline.

Fabric Selection Matrix

Medium
Linen
(5-7oz)

Best Choice

Presses crisply,
softens with wear.
(Note: Must pre-wash
twice. Needle: 80/12).

Cotton
Lawn

Beginner Substitute

Highly stable on
the cutting mat,
minimal fraying.

Double
Gauze

Warm Climates

Breathable two-layer
cotton, requires
gentle handling to
avoid edge distortion.

Chambray

Linen-Look

Good body, presses
well, highly stable
with minimal fraying.

The Golden Rule of Linen

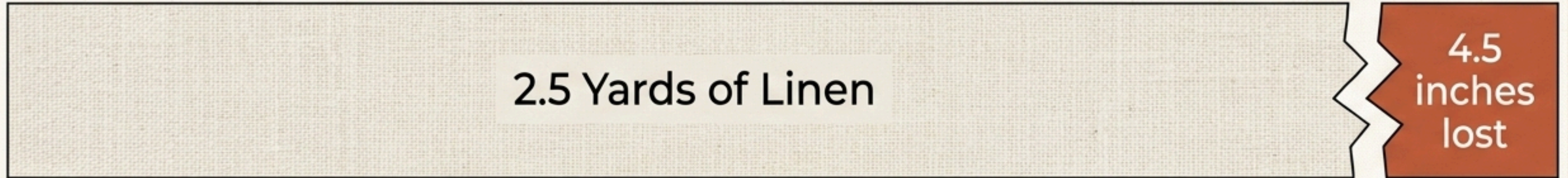

Linen shrinks 3–5% in the first wash. On 2.5 yards, skipping the pre-wash removes 4.5 inches of length that cannot be fixed after sewing.

1. Zigzag raw yardage edges.
2. Wash twice on warm.
3. Dry at finished-garment heat.
4. Press flat with steam before cutting.

The Sizing Diagnostic

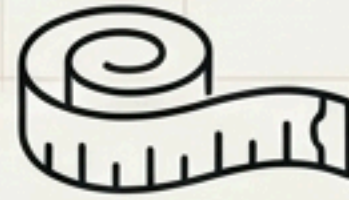

Measure High Bust
(under arms) & Full Bust.

SIZE	HIGH BUST			FABRIC NEEDED
XS / S	31" - 34"	33" - 36"	33" - 36"	1.75 yd / 60"
M / L	Difference is < 2 inches	37" - 40"	37" - 40"	Difference is > 2 inches
XL / 2X	39" - 43"	41" - 45"	41" - 45"	2.5 yd / 60"

Cut standard size based on High Bust.

Cut High Bust size + apply Full Bust Adjustment (FBA) to front bodice before cutting linen.

"Easy to sew, didn't fit me at all."

Cutting by full bust rather than high bust is the #1 reason a boxy shift fails to fit.

Anatomy of the Pattern (Women's Range)

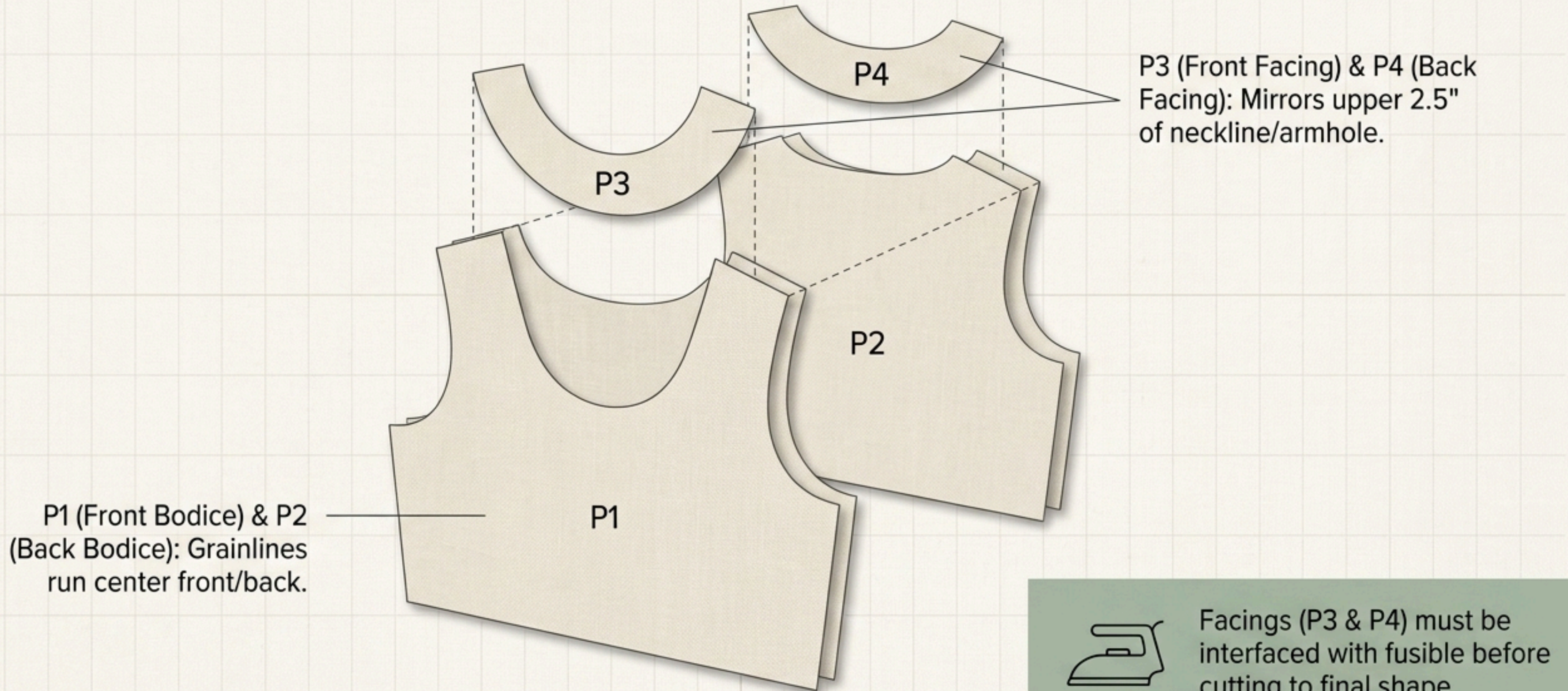

Facings (P3 & P4) must be interfaced with fusible before cutting to final shape.

The 3-Step Pre-Cut Check (No Muslin Required)

Step 1:
Verify Grain.

Step 2:
Tissue Check.

Step 3:
Size Up if Unsure.

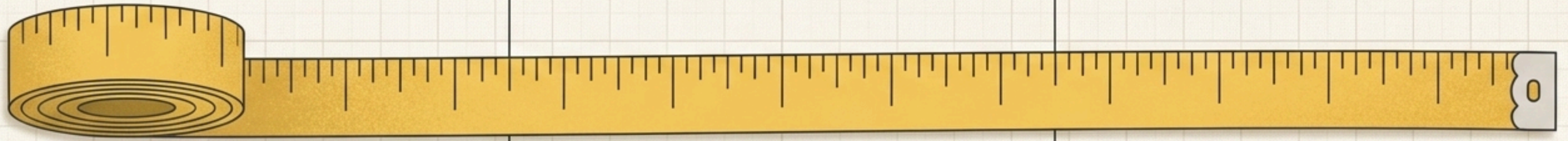

Arrow to selvage distance must match within 1/8" at both ends. (Do not stretch fabric to compensate).



Hold front pattern tissue to your shoulder to verify neckline depth and placement.



Side seams are easily recoverable; cutting too small is not.

Construction Phase 1: Securing the Edges

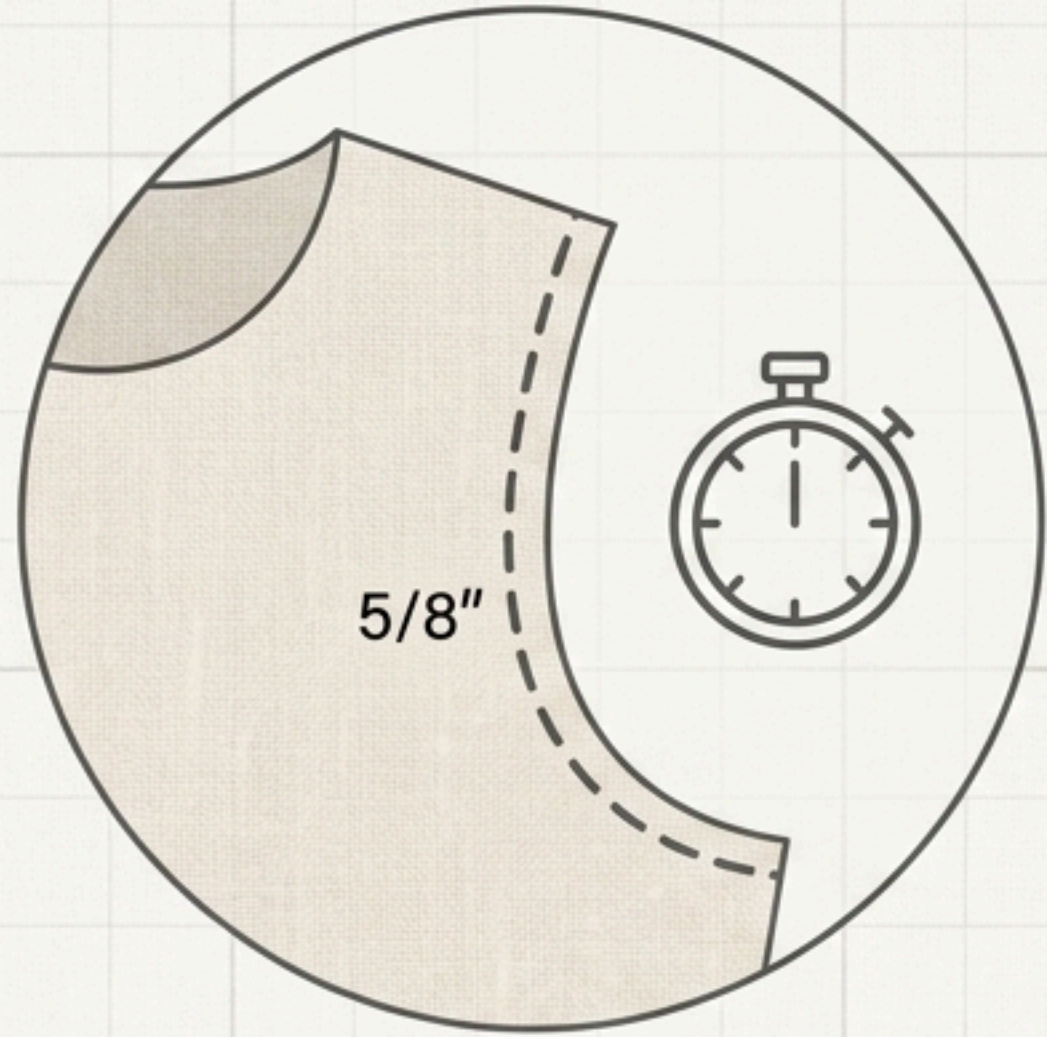

The 2-Minute Mandate

Staystitch all curved edges (necklines and armholes) at 2.0mm immediately after cutting. Linen stretches irreversibly during handling.



Finish Allowances First

Choose your seam finish (Serge, Zigzag, or French) before garment assembly begins.

Seam Finishes Side-by-Side



French Seam

Cleanest internal finish. (Sew wrong sides $3/8$ ", trim, right sides $1/4$ ").

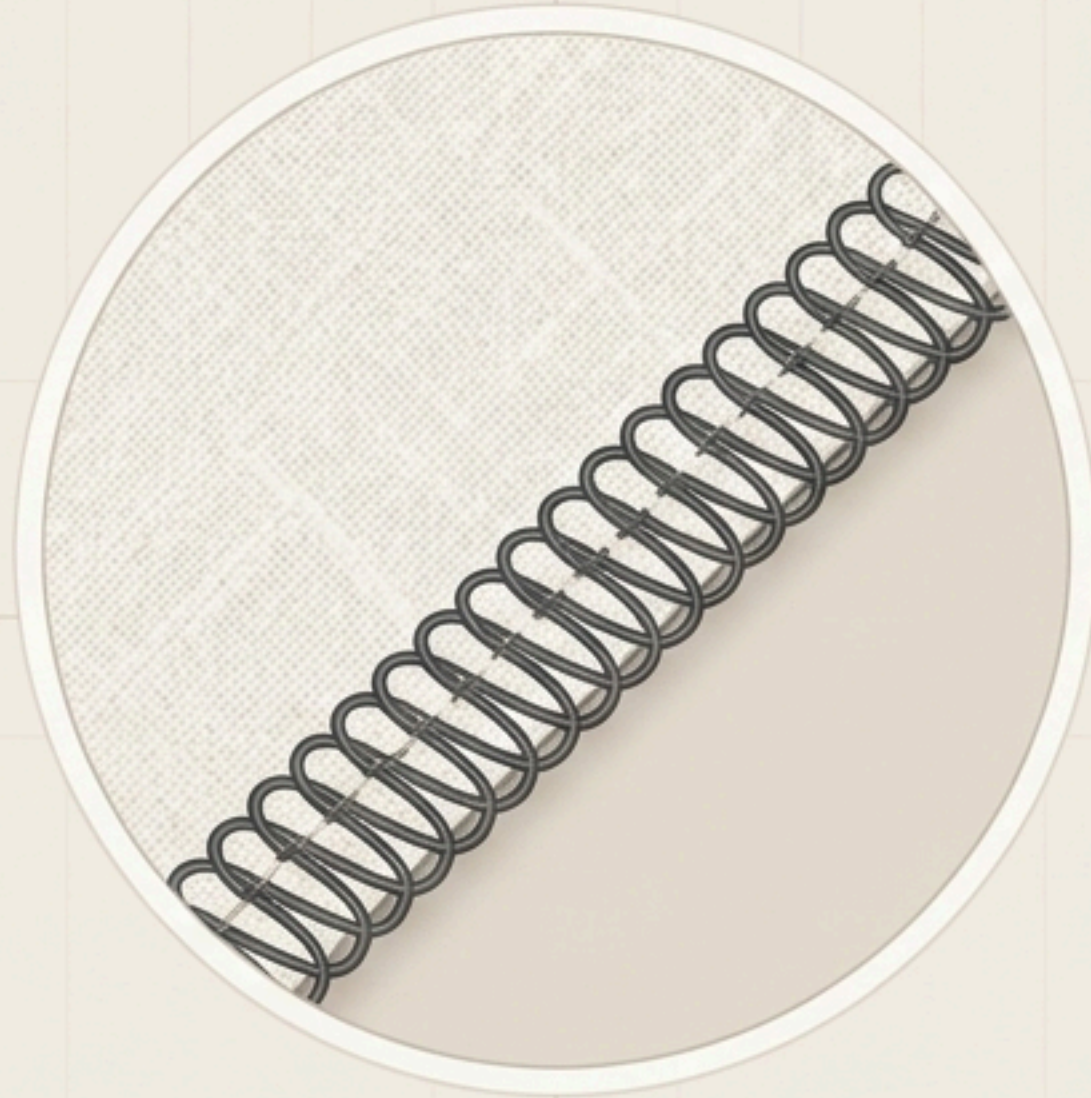

Serger

Fastest, professional edge control.



Zigzag

Highly accessible domestic option (3-4mm width, 2.5mm length).

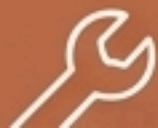

Fix-It Note: If the zigzag tunnels along the linen edge, reduce presser foot pressure by one step.

Construction Phase 2: Assembly & Pressing

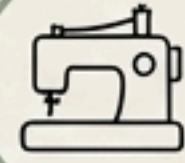

Step 1: Shoulder Seams.

Sew front to back (5/8" allowance, 2.5mm length).



Press open immediately.

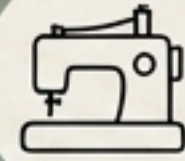

Step 2: Neckline Facing.

Apply facing, clip curves, understitch 1/8" from seamline to prevent rolling.

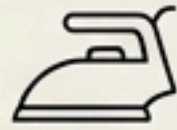

Press to inside.

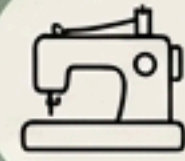

Step 3: Side Seams.

Sew front to back.



Press open immediately.

A seam crossed before pressing creates a permanent, unfixable ridge.

The Kids Variant: Key Differences



CHEST	APPROX AGE	DRESS LENGTH	FABRIC NEEDED
18" - 20"	2 - 3Y	18" - 20"	1 yd / 44"
21" - 23"	4 - 5Y	22" - 24"	1.25 yd / 44"
24" - 26"	6 - 7Y	25" - 28"	1.5 yd / 44"

Sizing Rule:

Size strictly by Chest measurement, not age.

The Proportional Shift:

Children's head-to-body ratios are larger. You must check that the neckline opening **circumference equals** the head circumference + 2" ease before cutting.

Facing Efficiency (Piece K4):

Uses a single, combined facing piece that finishes both the neckline and armholes in one pass.

The Finishing Polish



The Hem: Fold raw edge 1/4" and press. Fold again at 1" and press. Topstitch from the right side.

1

Final Press Protocol:

1. Neckline (from the inside).
2. Side seams (from the inside).
3. Hem (from the right side using a pressing cloth).

2

The ROI of Handmade

\$25 in materials ÷ Worn 50 times over two summers
= **\$0.50 cost per wear.**

Troubleshooting Dashboard

Symptom	Cure
Neckline edge is already stretched. →	Re-staystitch at 1.8mm, slightly easing fabric to draw it back to the cut line.
Facing rolls to the outside. →	Open neckline, ensure understitching is applied 1/8" from seamline, re-turn.
Drag lines pull back at the hip. →	Let out back side seam by 1/4" between hip and hem.
Body is altogether too wide. →	Take in side seams (max 1" per side). Baste and fit before permanent stitching.

The Foundation is Set

The true success of a first garment isn't whether it looks flawless in a photo—it's whether you confidently reach for it on a Tuesday in August.

Keep this blueprint at your cutting table. The straight seams, faced necklines, and precision pressing you mastered here are the exact same skills required for your next hundred projects.

