

Start Sewing Toddler Clothes Today: A Complete Pattern and Flat-Construction Guide

Master the flat-construction method to sew elastic-waist pants (sizes 2T–5T) and an A-line dress with zero frustration.

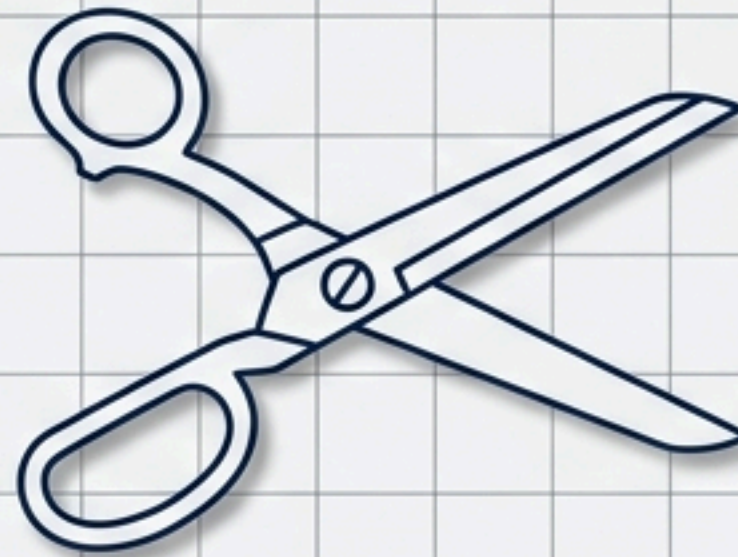
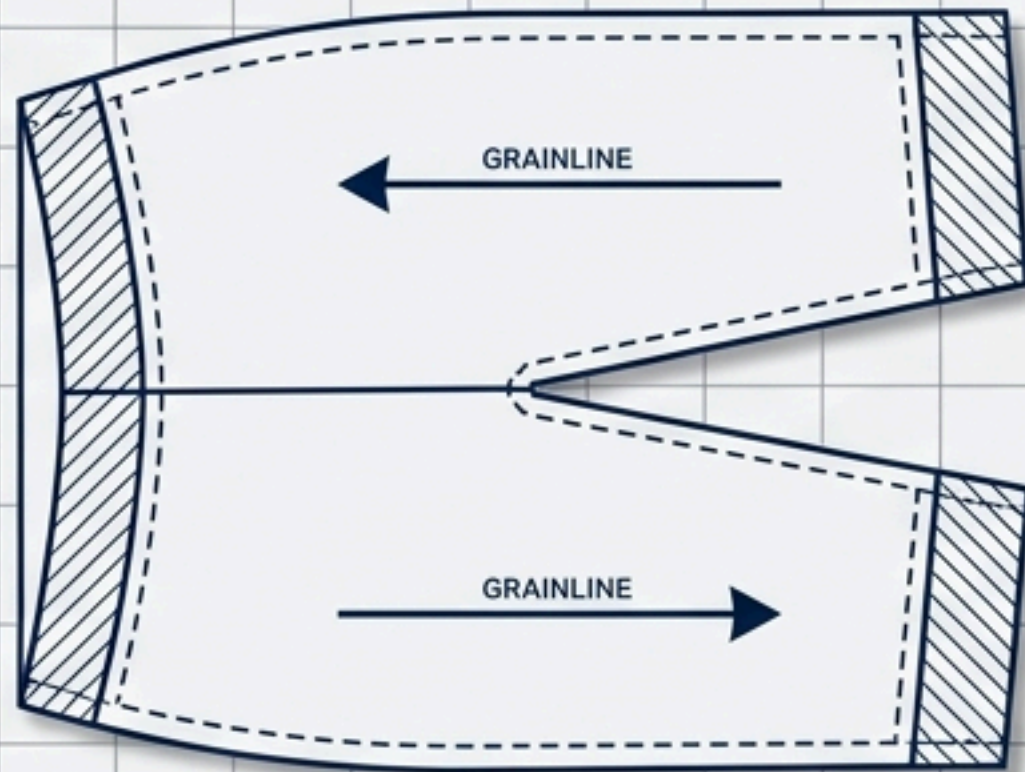

Skill level: True Beginner

| Includes free reference templates

Why Toddler Clothes Are the Ultimate Beginner Sewing Project

Cognitive Map

The Old Way

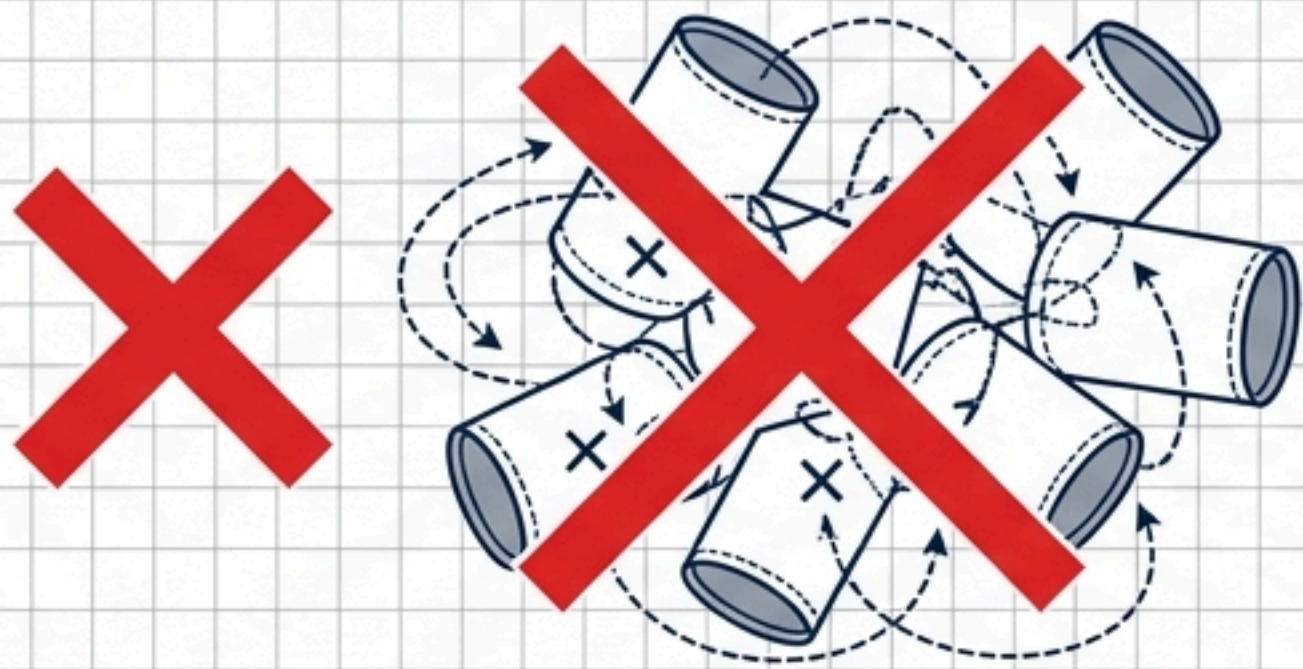

FRUSTRATING & COMPLEX

The Flat Construction Method

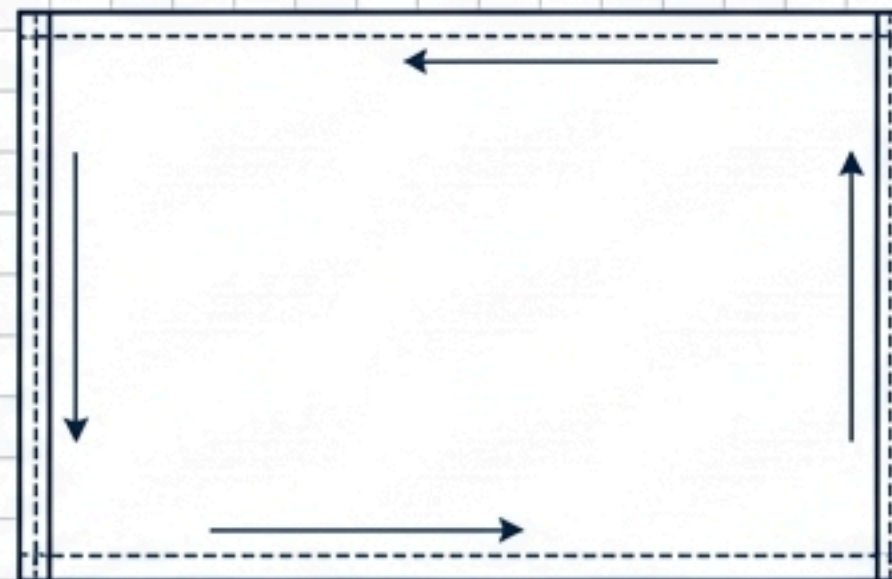

EFFICIENT & ACHIEVABLE

Small pieces and low fabric waste.

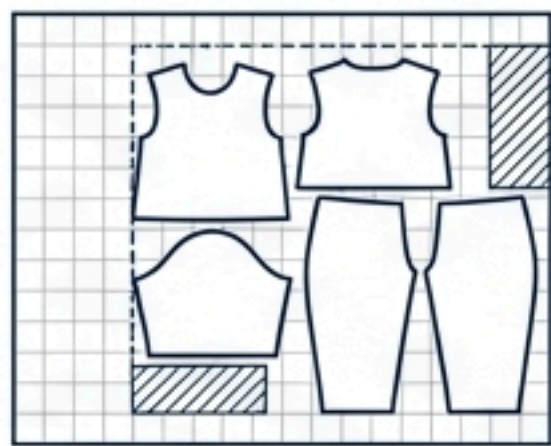

Efficient
Pattern Tetris

Uses
< 1 Yard/Meter

Forgiving fits with no zippers or buttonholes.



Elastic Waists
& Necklines

Simple,
Flexible
Closures

Fast wins: 60-90 minutes for pants, 2-3 hours for a dress.



60-90
MINS



PANTS
FINISHED



2-3
HOURS



DRESS
FINISHED

↑ Rapid Project Completion
& Confidence Boost

Gather the Essential Tools and Supplies

Hardware



Any home model



Straight pins or pattern weights



Iron and pressing surface



Safety pin for threading



Fabric scissors or rotary cutter with mat



Tape measure



Straight pins or pattern weights



Seam ripper

Consumables



0.75 to 1 yard of 44/45-inch medium-weight cotton



3/4-inch braided elastic



All-purpose polyester thread



Universal 80/12 needle (or Ballpoint 80/12 for knits)

Select the Right Fabric (and Avoid Common Beginner Traps)

Diagnostic Fabric Matrix		
Garment	Ideal Fabric	Why It Works
Pants	Quilting cotton, poplin, twill	Stable, easy to press, feeds evenly
Dress	Quilting cotton, lawn	Lightweight, good drape
Pajamas	Cotton flannel	Soft, warm, beginner-friendly
Stretchy Tops	Cotton interlock	Does not curl at edges like single jersey



First-Timer Warning: Avoid silk, chiffon, heavy denim, and slippery polyester. These fabrics fight the machine and punish small errors.



Repurpose an adult cotton shirt from a thrift store—one shirt yields enough fabric for a full pair of toddler pants.

Measure the Child and Calculate Fabric Yardage

Master Sizing Hub

Size	Chest	Waist	Hips	Inseam	Dress Length	Pants Yardage	Dress Yardage	Elastic Length
2T	21	20	22	10	17	0.5 yd	0.75 yd	18
3T	22	21	23	12	19	0.625 yd	0.875 yd	19
4T	23	22	24	14	21	0.75 yd	1.0 yd	20
5T	24	22.5	25	15.5	23	0.875 yd	1.125 yd	20.5



Rule 1

All measurements include 1-2 inch ease.



Rule 2

Cut elastic to actual waist minus 1 inch.



Rule 3

Yardage based on 44/45-inch fabric (add 0.25 yd for swatches).

Pants Pattern Anatomy: Cut Two Identical Pieces

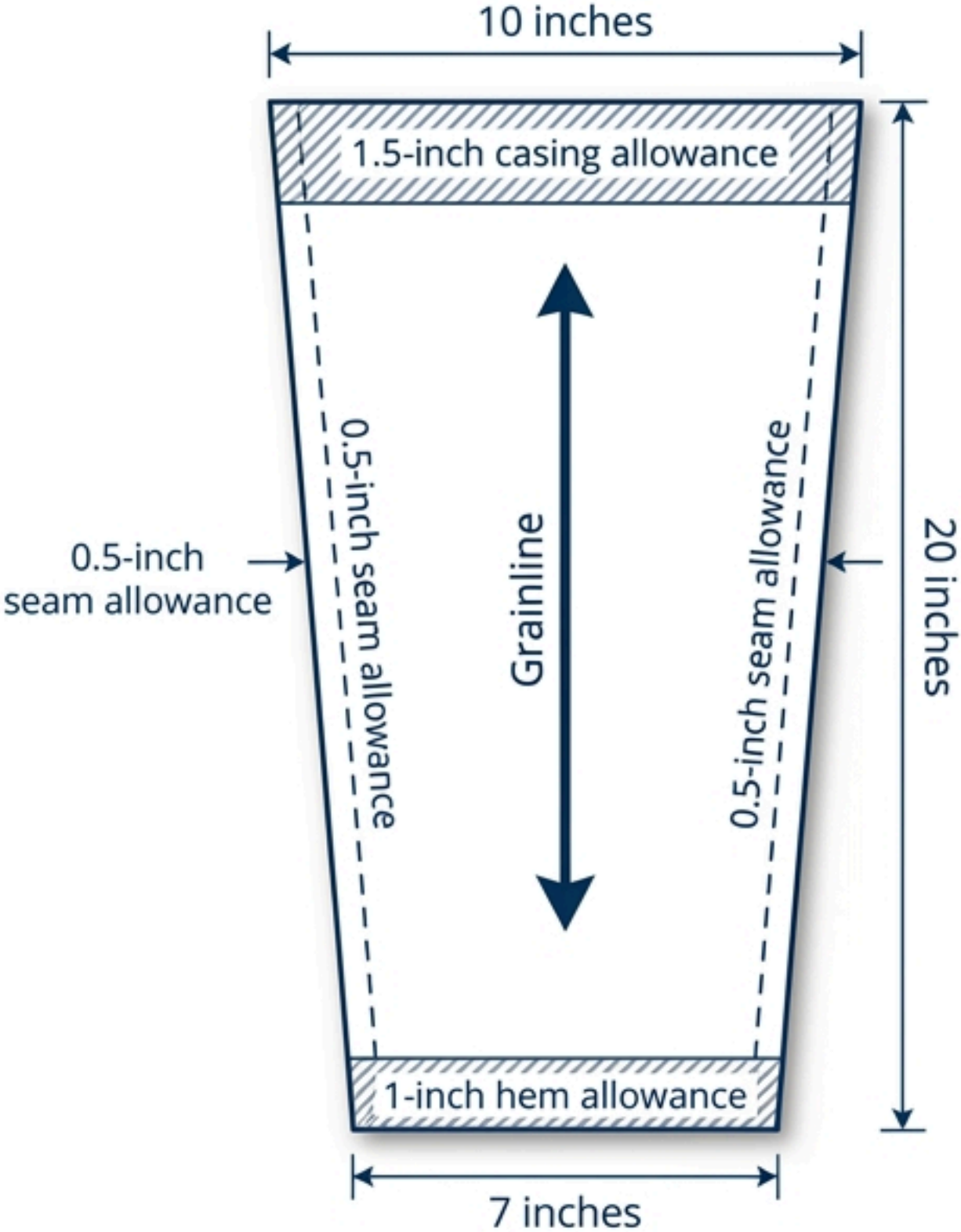

This is a scaled reference diagram for Size 3T. Measure and mark directly onto fabric, or enlarge to stated dimensions.

Dress Pattern Anatomy: Cut on the Center Fold

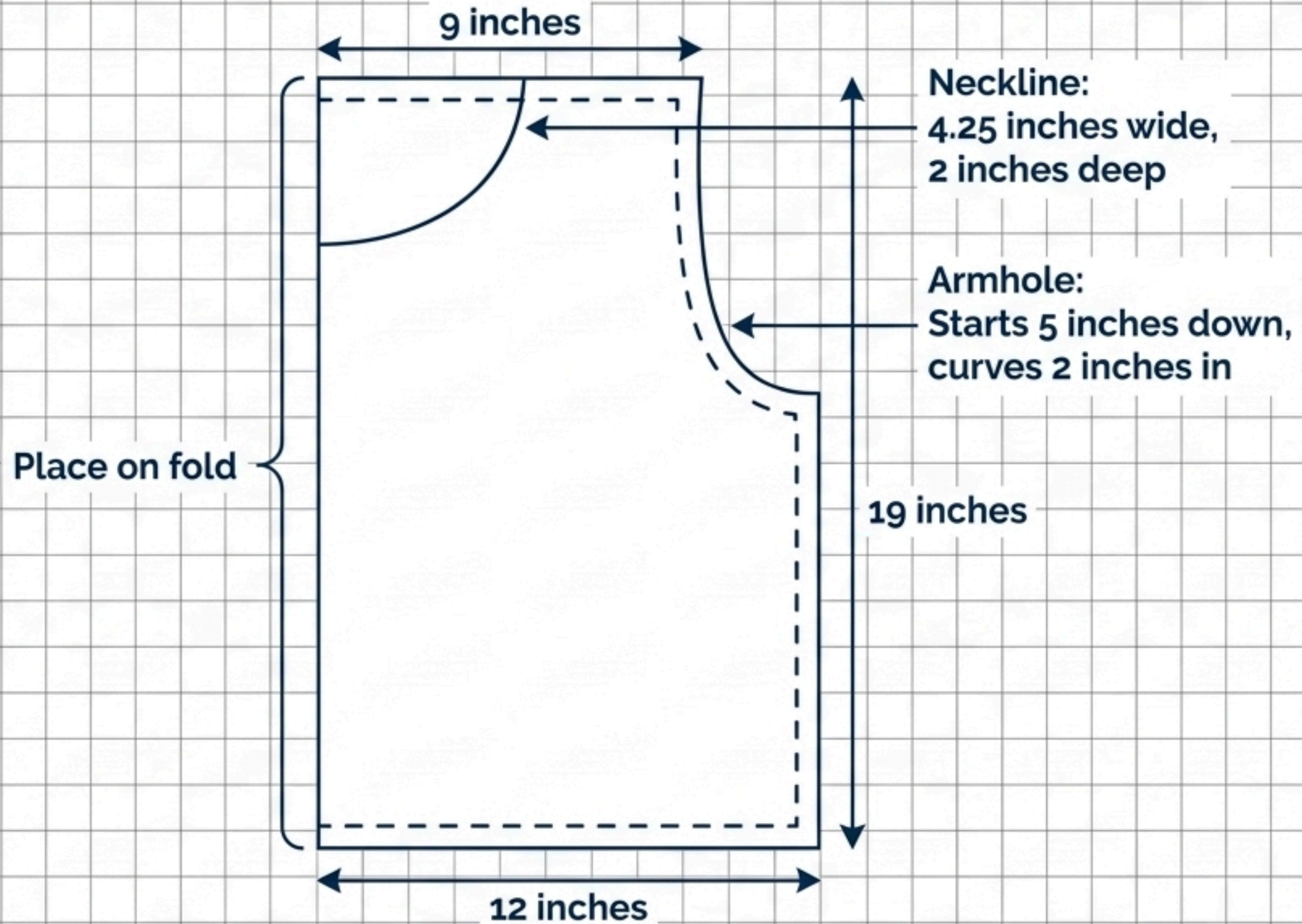

Cut 2 on fold (front and back are identical).

Position Pattern Pieces on the Cutting Board

Pants Layout

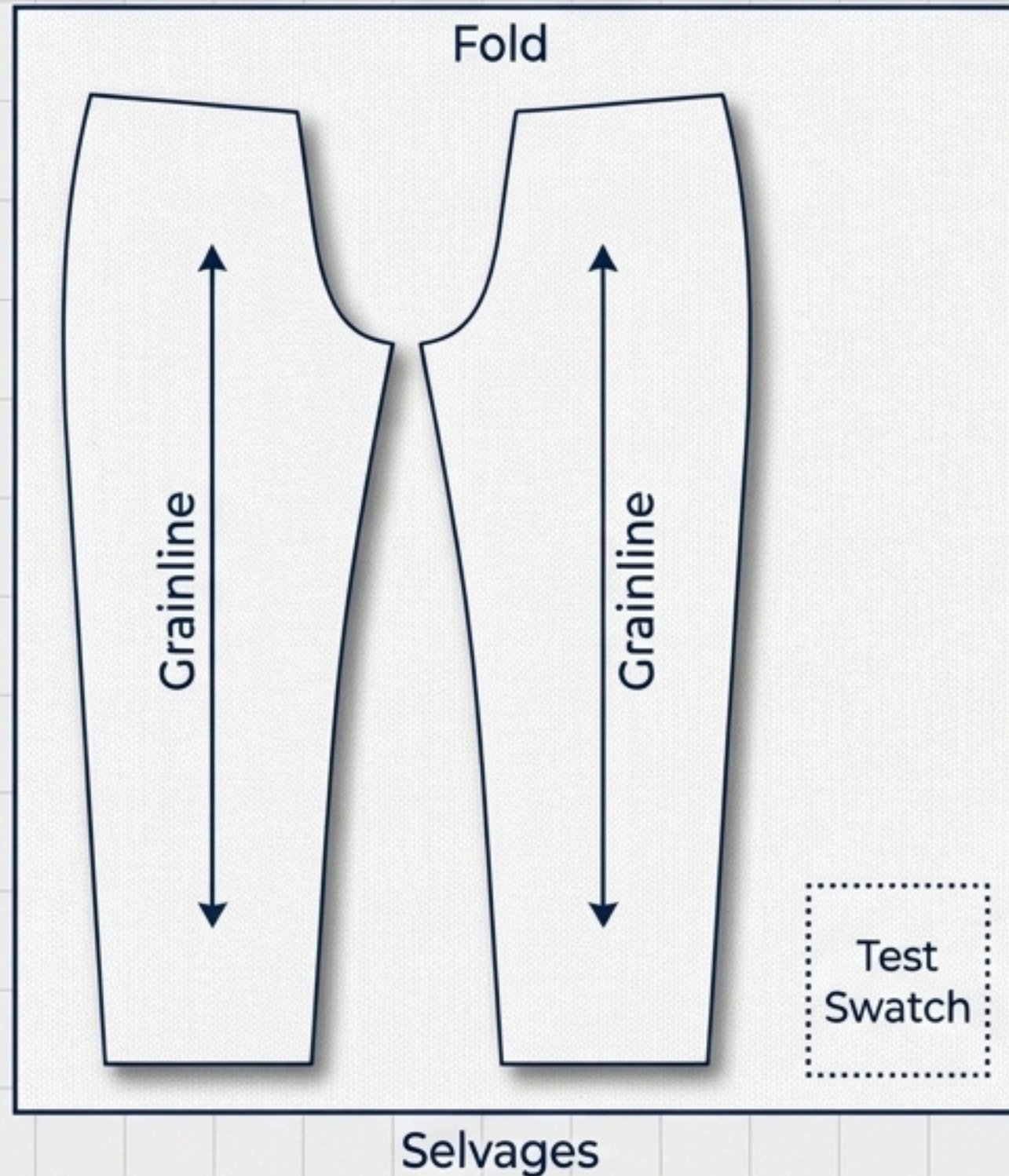

Dress Layout

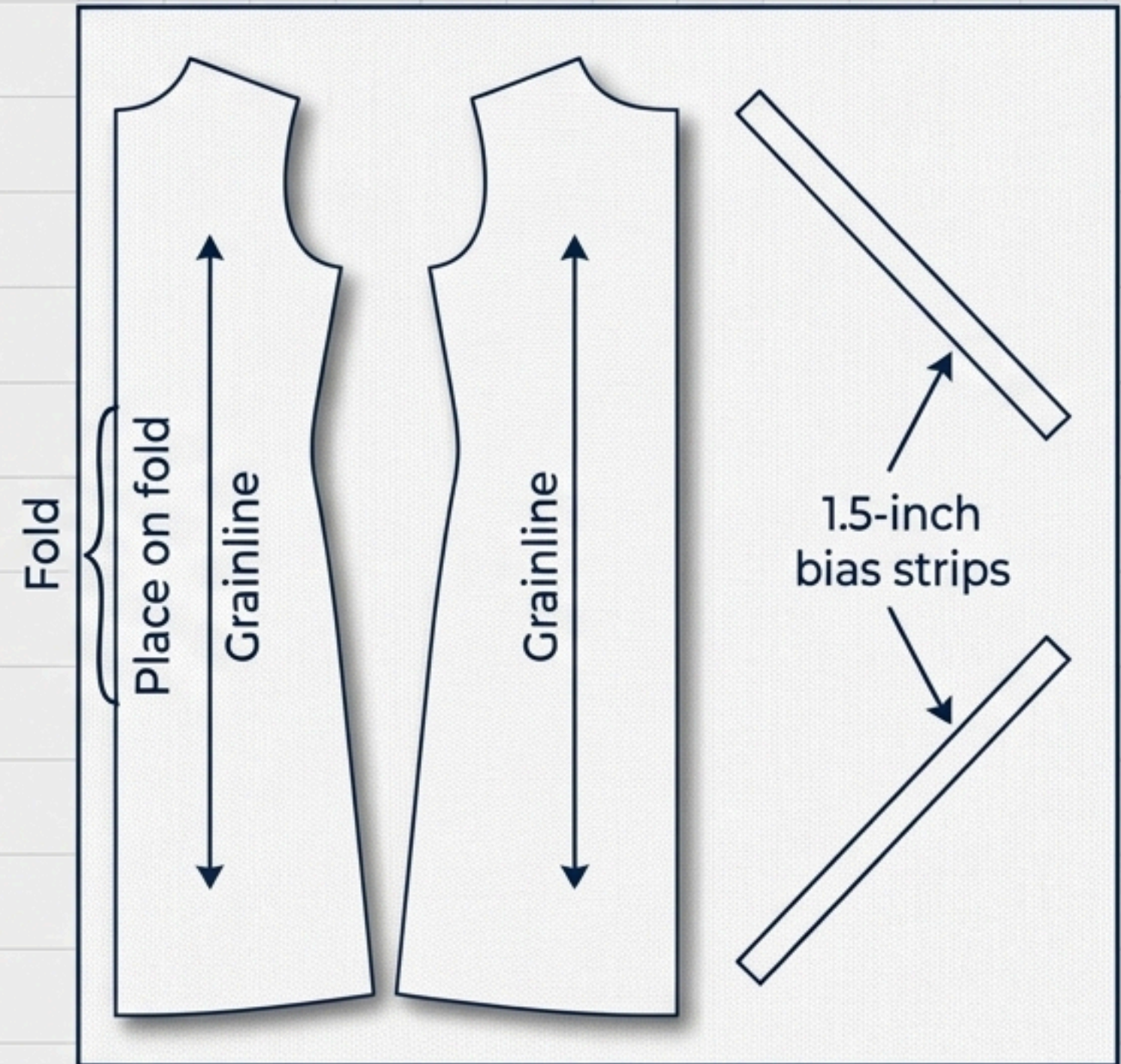

Process Rule: Pin or weight the pattern. Cut with sharp scissors or a rotary cutter without lifting the fabric.

“Set Up the Machine Before the Needle Hits the Fabric” in Tailor’s Navy

Machine Dashboard



Needle:

Universal 80/12 (woven)
or Ballpoint 80/12 (knit). matching top & bobbin



Thread:

All-purpose poly



Stitch Length:

2.5mm (seams),
3.0mm (casings)



Tension:

Default 4



Foot:

Standard zigzag



40% of stitch problems are threading errors. Re-thread the machine completely before starting any new project, even if it looks correct. Always test stitch on a fabric scrap first.

Pants Phase 1: Hem and Create Casings While Flat

Step 1: Hem the Legs

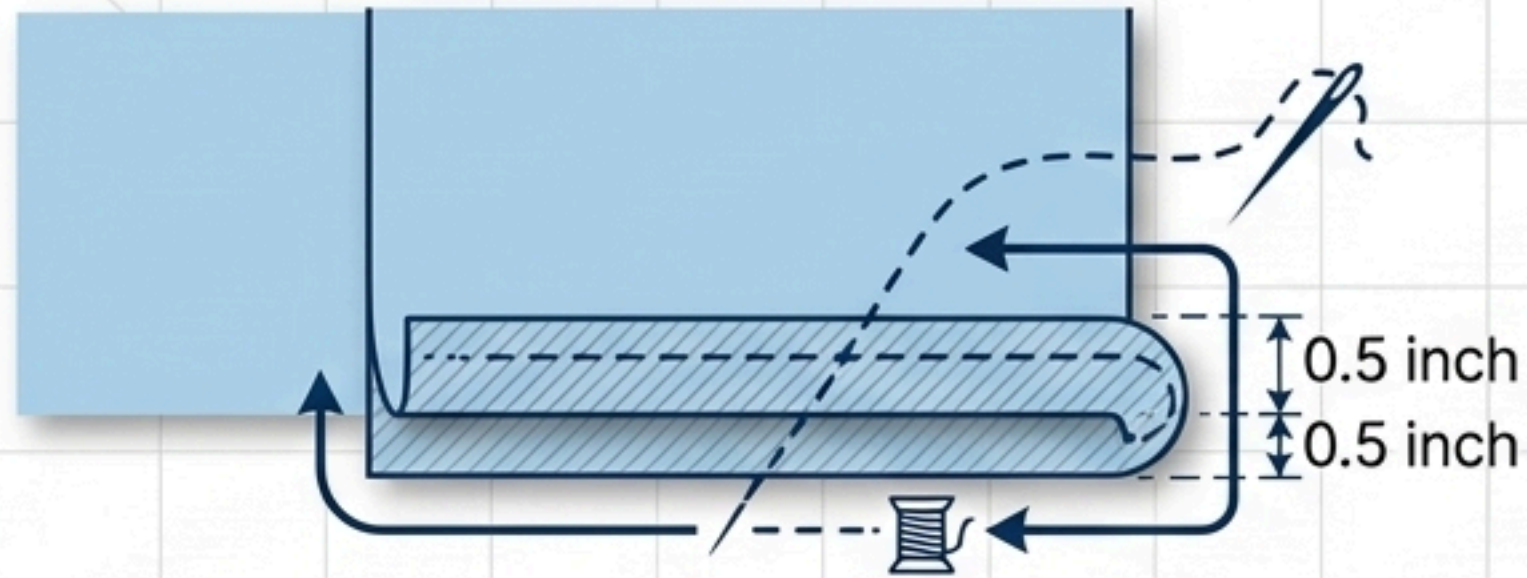

Fold 0.5 inches twice. Stitch close to the inner fold on both flat rectangles.

Step 2: Waistband Casing

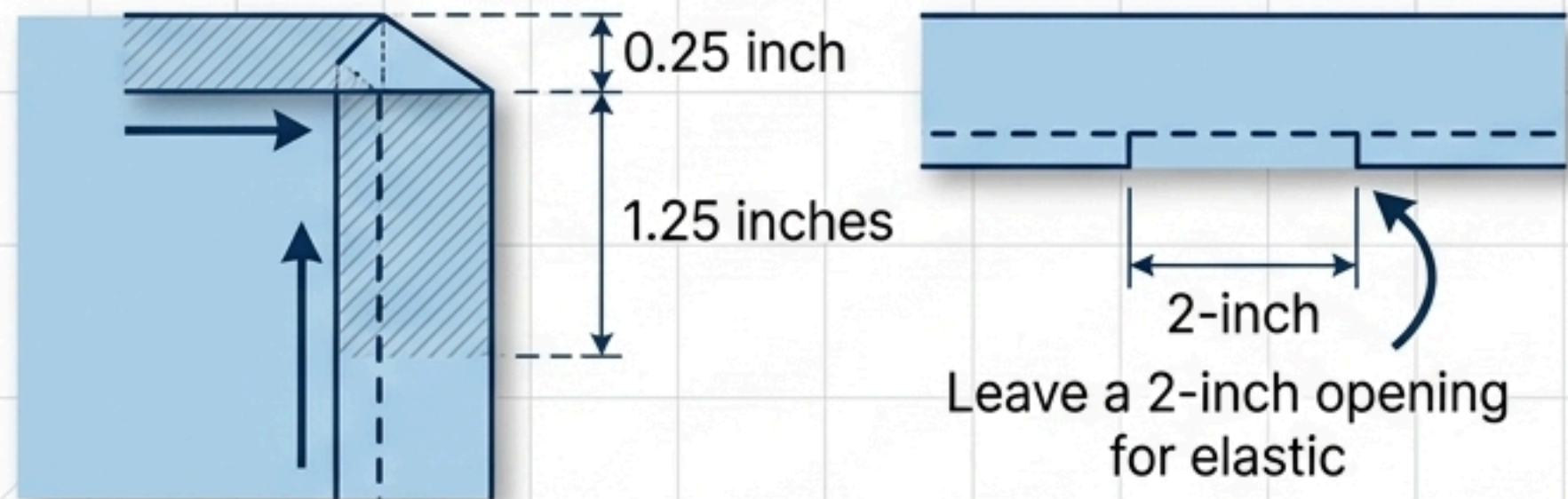

Fold 0.25 inch down, then fold 1.25 inches. Stitch close to the inner fold, leaving a 2-inch opening.



Fix-It Tip: Press every fold before you stitch. The iron does half the work. A 1.25-inch casing ensures $\frac{3}{4}$ -inch elastic slides through without bunching.

Pants Phase 2: Close Seams and Lock the Elastic

Step 3: Inseam

(Right Side Together)

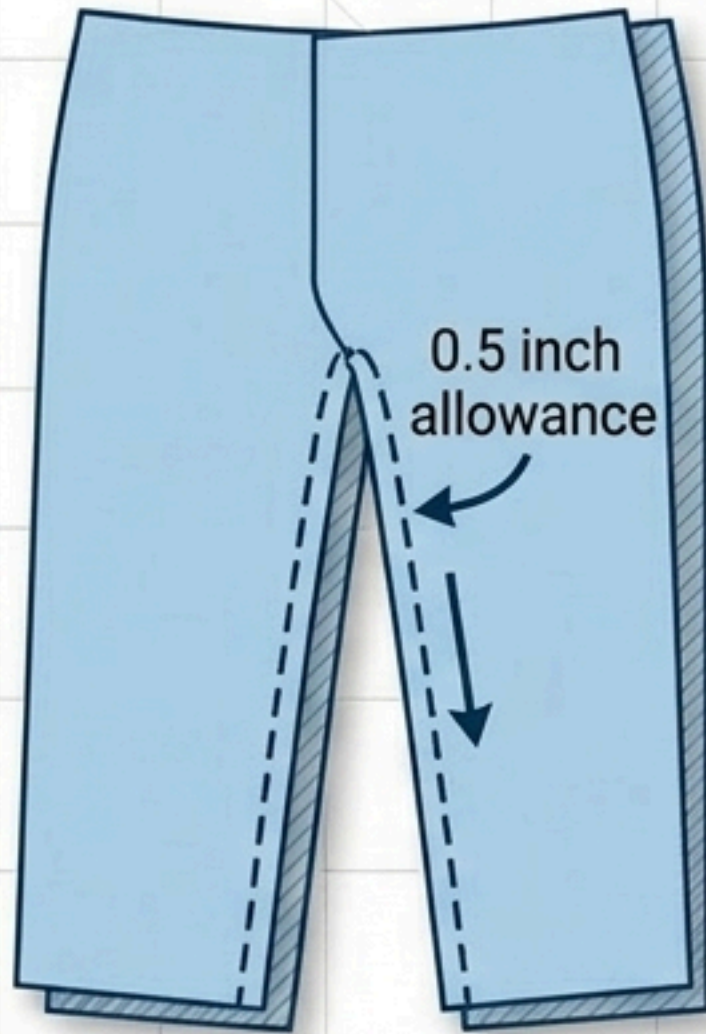

Stitch the curved inseam with 0.5-inch allowance. Backstitch ends.

Step 4: Side Seams

0.5 inch allowance

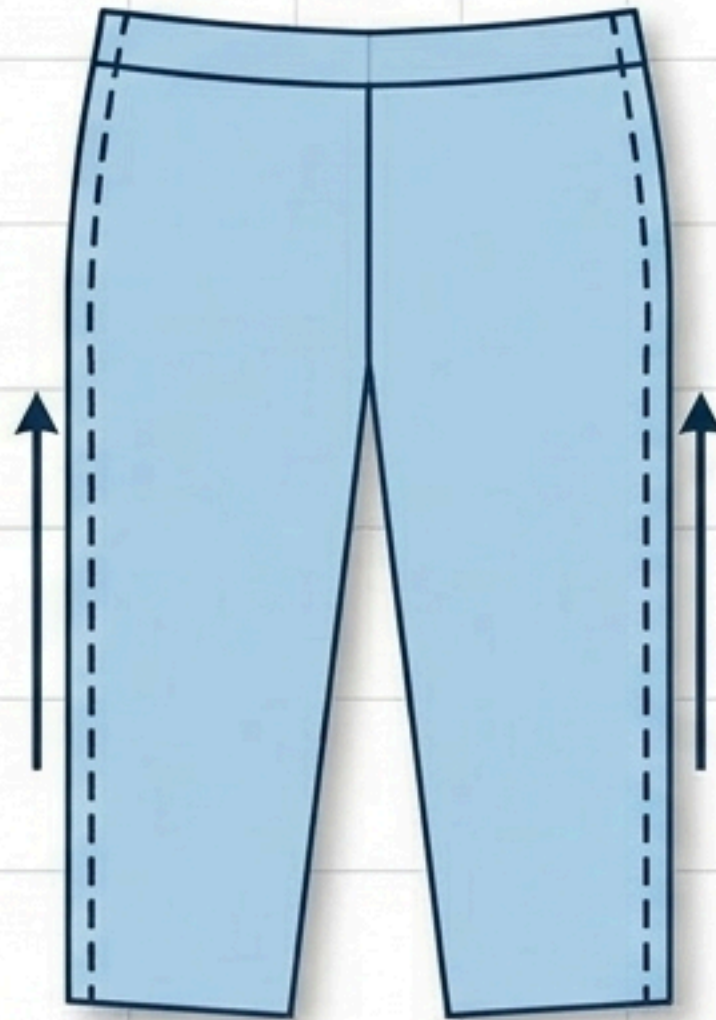

Stitch outer side seams (0.5-inch allowance).

Step 5: Insert Elastic

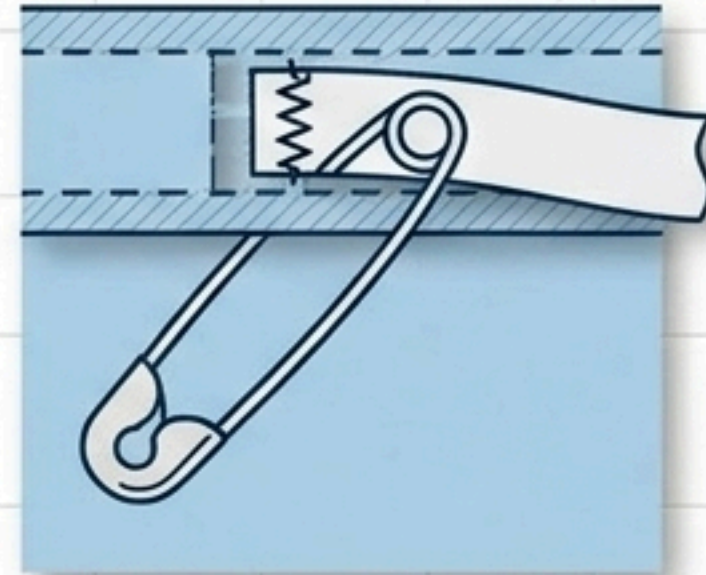

Thread elastic via safety pin. Overlap ends by 0.5 inch and zigzag stitch. Close the 2-inch casing gap.

Step 6: Lock Elastic

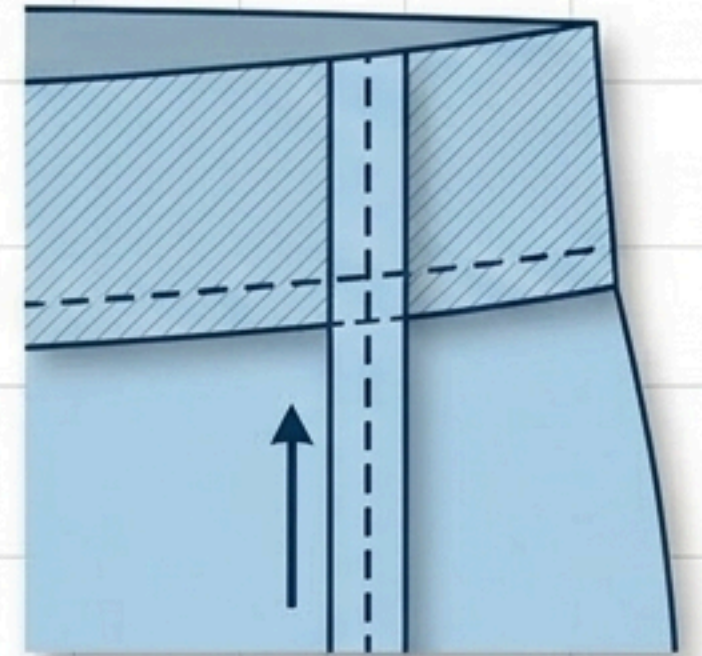

Topstitch directly through all layers at side seams to prevent twisting.

Dress Assembly Sequence: Finish Edges Before Closing the Tube



1 Neckline

Finish flat (fold 0.25 inch, then 0.5 inch, stitch).



2 Armholes

Finish all four curves flat (same fold method).

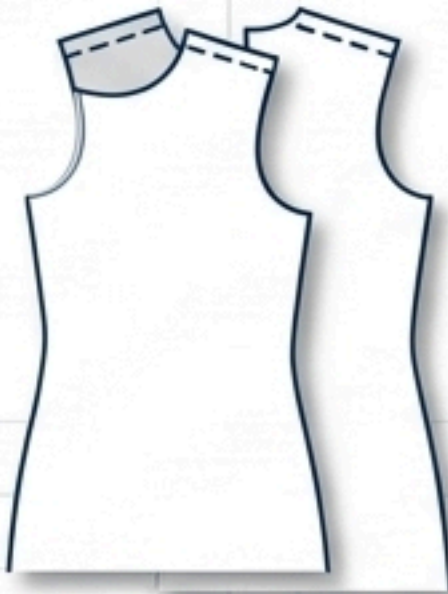

3 Shoulders

Sew Right Sides Together (0.5 inch seam, press open).

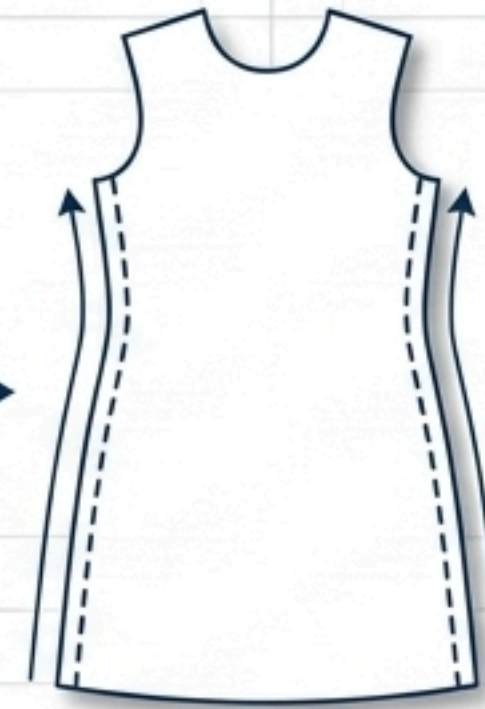

4 Side Seams

Sew from armhole to hem (0.5 inch seam).

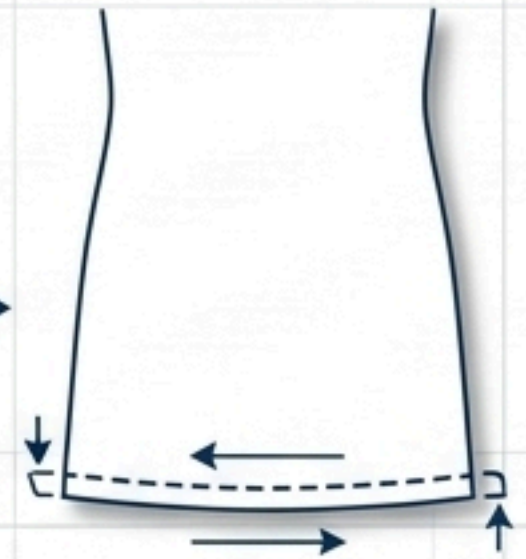

5 Hem

Fold 0.5 inch, then 1 inch, stitch.







Fix-It Tip: Press every fold before you stitch. The iron does half the work.

Fix-It Note

If your neckline or armhole finish looks bumpy, you pressed after stitching instead of before. Press the fold into the flat fabric first, then stitch. The fabric will remember the crease.

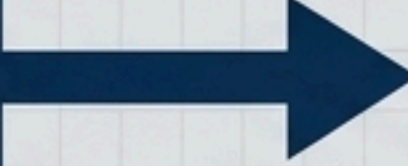
Troubleshoot and Fix Common Machine Problems

If this happens...		Then do this...
Seam puckers on lightweight cotton		Reduce presser foot pressure (if adjustable), switch to a new size 80/12 needle, and completely re-thread the machine. Test on a scrap.
Skipped stitches on knit fabric		Switch to a ballpoint needle; increase stitch length to 3.0mm.
Elastic twists inside the casing		Pin at side seams before closing; topstitch vertically through all layers at side seams.
Bobbin thread shows on the top side		Top tension is too tight; reduce the dial by one number.
Top thread loops underneath the fabric		Re-thread the bobbin; check the entire top threading path.



Fix-It Note

If your seam puckers on lightweight cotton, reduce presser foot pressure (if adjustable) and switch to a new size 80/12 needle. Re-thread the machine completely. Test on a scrap before continuing. 40% of stitch problems are threading errors.

Hack the Pattern to Grow with the Child

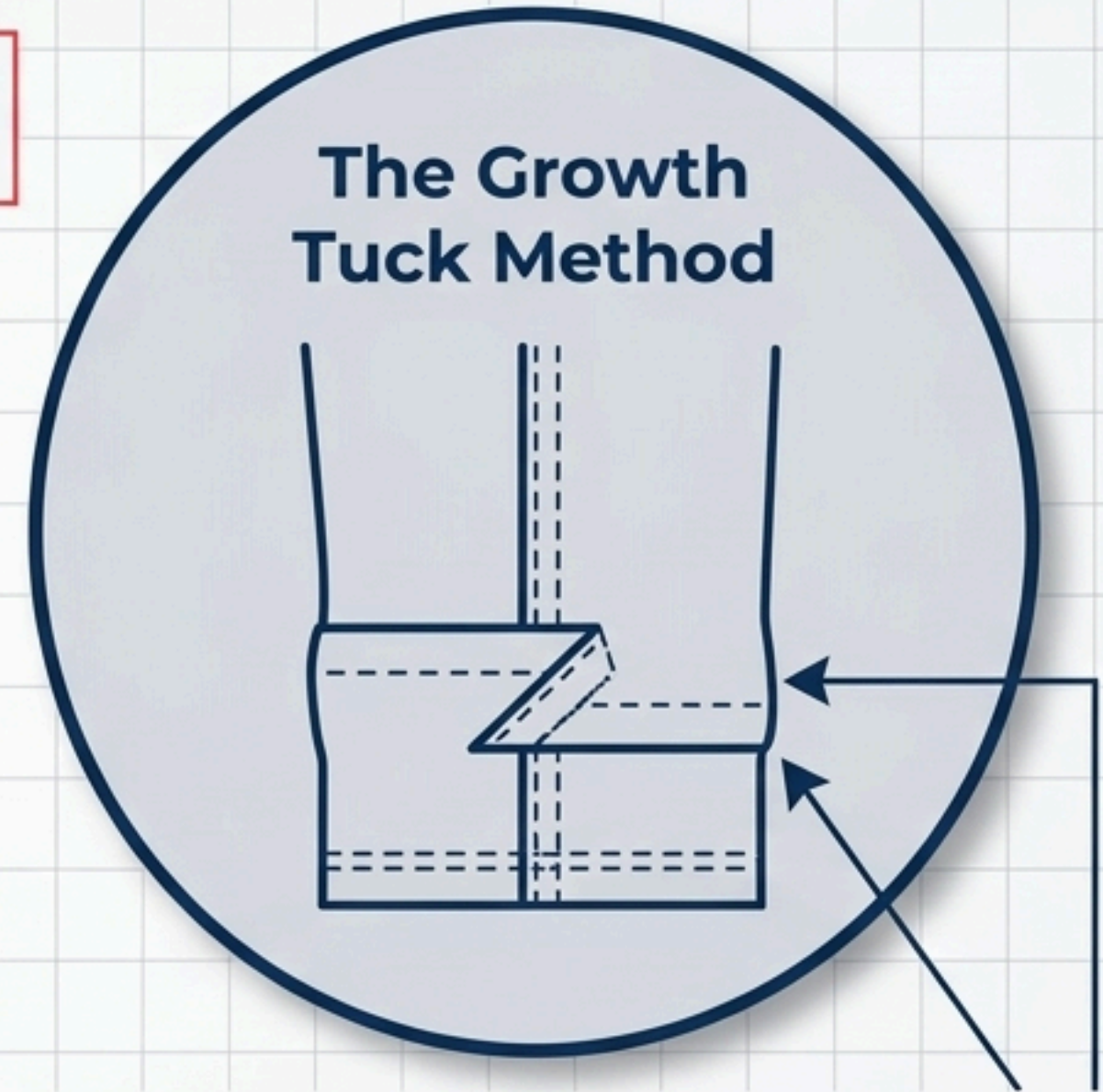
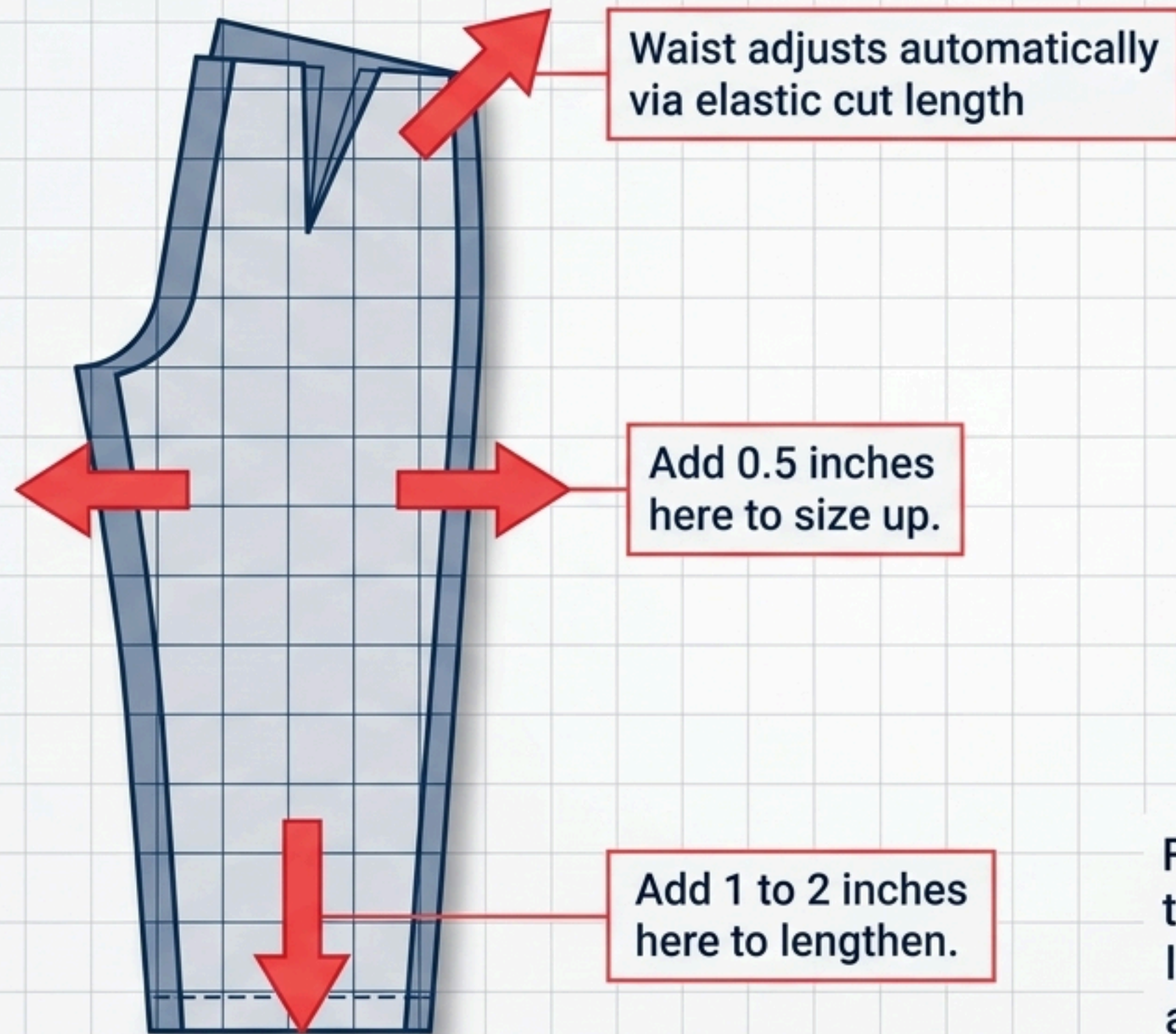

Fold and stitch a 1-inch horizontal tuck above the hem line. When the child outgrows the length, simply rip trip this seam to release an extra inch of fabric instantly.

Progress to New Projects Safely

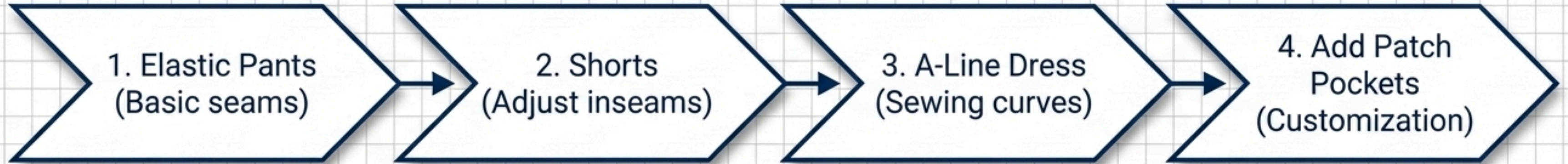

Safety Note

For sleepwear, CPSC regulations require either snug-fitting construction or flame-resistant fabric for children's sizes 9 months through 14 years. Check cpsc.gov for current requirements before sewing pajamas. Avoid loose ribbons, buttons, or drawstrings on toddler garments.

Ready to build your toddler's wardrobe? Download more free templates and technique tutorials at Sewing.com.